

(12) UK Patent Application (19) GB (11) 2 108 228 A

BEST AVAILABLE COPY

- (21) Application No 8228877
 (22) Date of filing 21 Sep 1982
 (30) Priority data
 (31) 816533
 (32) 21 Sep 1981
 (33) South Africa (ZA)
 (43) Application published
 11 May 1983
 (51) INT CL³
 F16L 13/14
 (52) Domestic classification
 F2G 24D3 25A
 B3J 15
 B3V 10
 U1S 1647 B3J B3V
 (56) Documents cited
 GB 1528230
 GB 1291208
 GB 0997721
 (58) Field of search
 F2G

- (71) Applicants
 Boart International
 Limited,
 (South Africa),
 6th Floor,
 Unitas Building,
 42 Marshall Street,
 Johannesburg,
 Transvaal,
 South Africa.
 (72) Inventors
 John Martin Holmberg
 (74) Agents
 Marks and Clerk,
 57-60 Lincoln's Inn Fields,
 London WC2A 3LS.

(54) Connection of drill tubes

(57) The invention provides a method of joining two rigid tubes 12 such as are used in drill stems wherein a nipple 10 internal to the tubes is threaded and screws into at least one of the tubes, the nipple being provided with a zone 20 of reduced internal diameter which registers with a cavity 22 in the internal bore of the tube, and the zone of reduced internal diameter is expanded outwards into contact with the tube to occupy the registering cavity in the tube and form a positive lock against tensile forces.

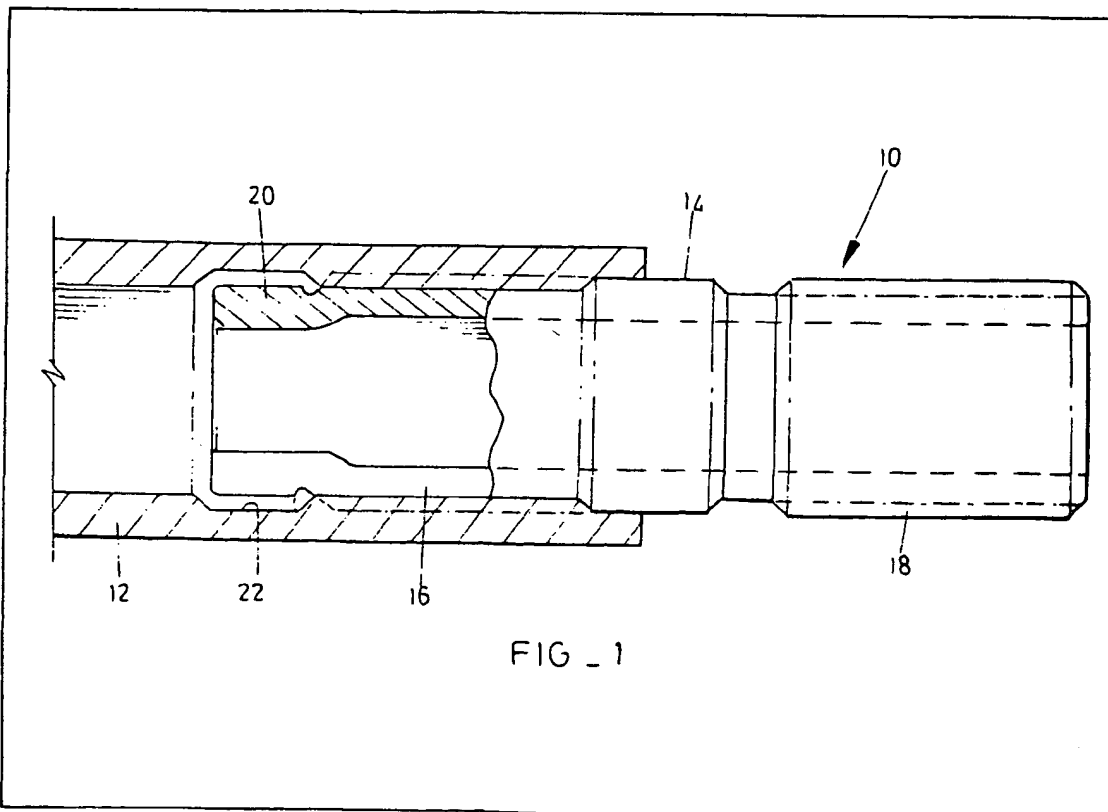

FIG. 1

The drawing(s) originally filed was/were informal and the print here reproduced is taken from a later filed formal copy.

GB 2 108 228 A

1/2

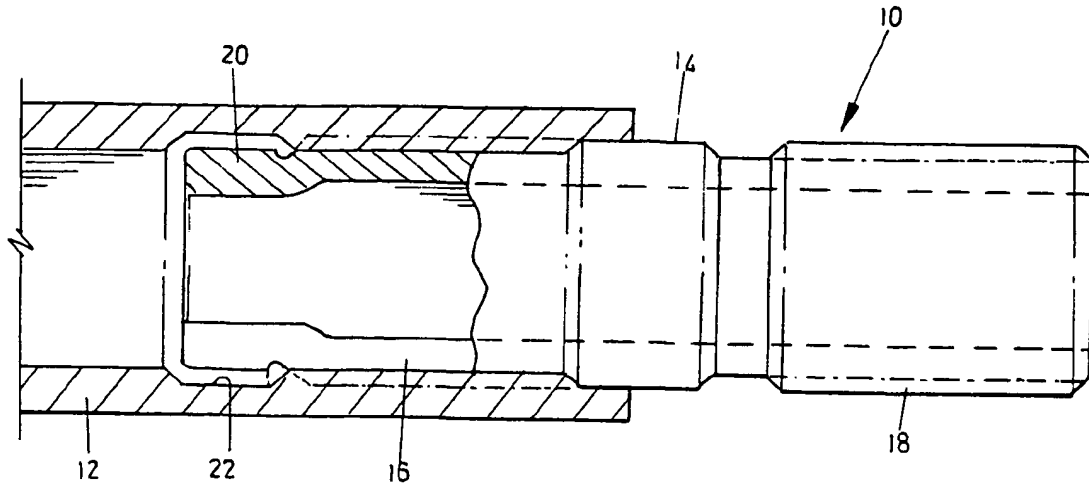

FIG. 1

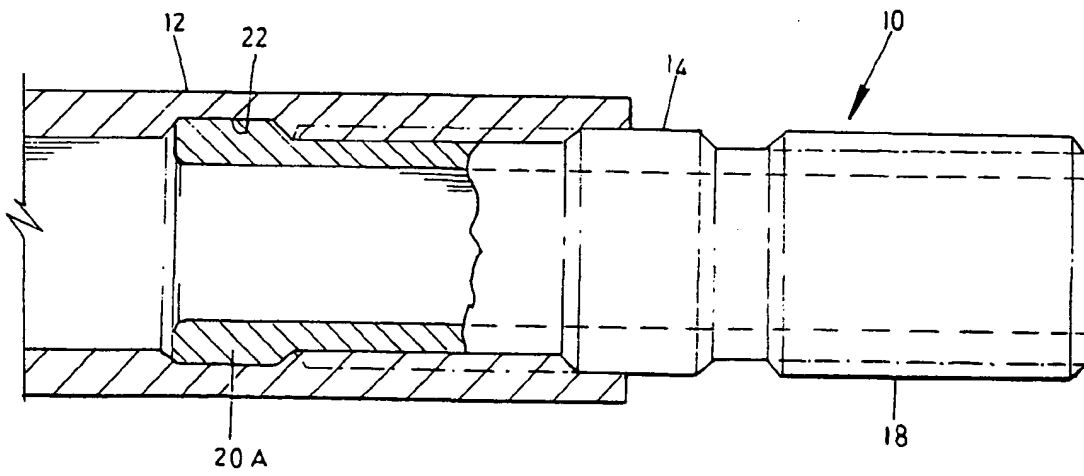

FIG. 2

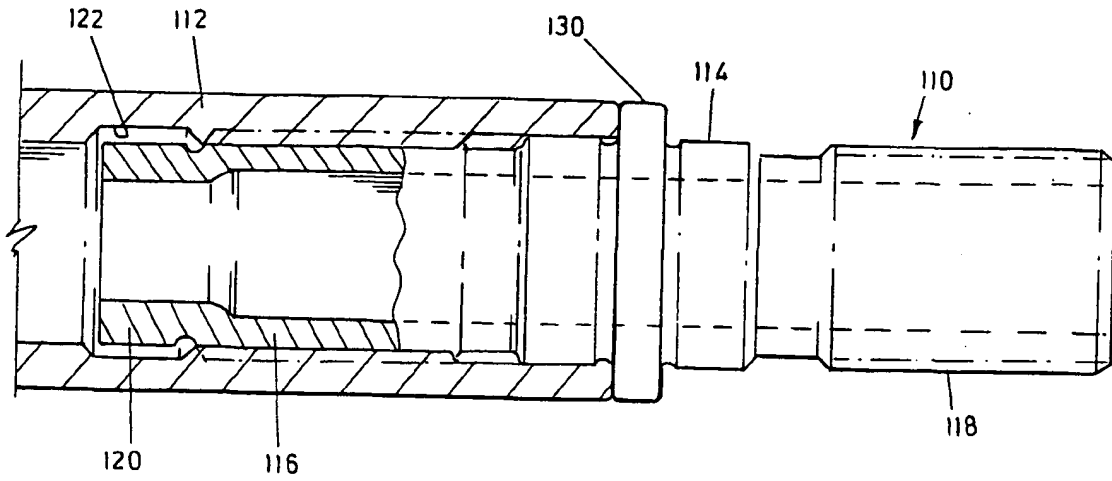

FIG. 3

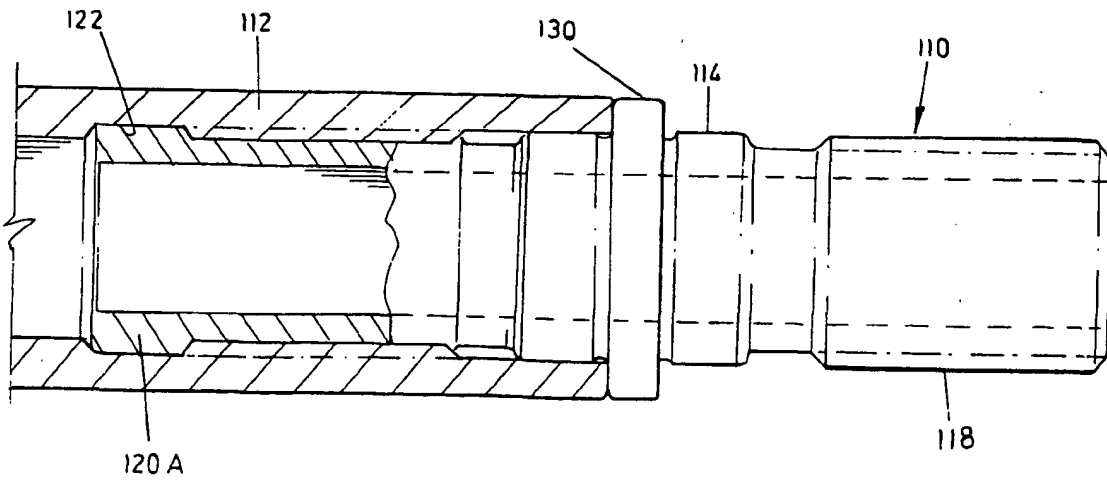

FIG. 4

SPECIFICATION

Connection of drill tubes

5 *Background of the invention*

This invention relates to the connection of one rigid tube such as a hollow drill stem to another by means of a threaded nipple or coupling. Assemblies of a string of connected drill stems or tubes of this kind are commonly used in circumstances where the task of adding to the drill string to increase its length is difficult and where it is desirable to ensure that the connection, once made is not accidentally negated.

It is often convenient where drill tubes are concerned to provide a joint which is suitable for transmitting axial as well as torsional loads without increasing the external diameter of the tubes at the joint, while still providing for a core to be extracted, if so desired, within the string of tubes.

United Kingdom Patents No. 1137310 and 1265715 describe joints which meet the above-mentioned objectives but also entail certain disadvantages. Patent No. 1265715 discloses one rod screwed into the end of another to form the joint. This joint requires special forging of the male section and there is no disclosure of any means to prevent the rods from unscrewing when the drill string is rotated. In patent No. 1137310 a tapering male/female joint is swaged and brazed along the interface. The tubes are of different malleability. However, this process will not give a rigid joint suitable for the transmission of large torsional forces. In addition, the taper of the interface will reduce the resistance of the joint to axial forces tending to pull the tubes apart. Neither of these patents disclose the use of a connector or nipple.

It is an object of the invention to overcome or mitigate the above problems.

40 *Summary of the invention*

According to the invention a method of forming a joint of high strength between two tubes of substantially similar high rigidity by means of a nipple which is no greater in external cross-section than the external cross-section of the tubes comprising forming on one end of the nipple a zone in which the internal diameter is reduced substantially relatively to the remainder of that part of the nipple intended to enter the tube, forming a zone of substantially enlarged inner diameter in a first tube to register with the reduced zone of the nipple, introducing the nipple into that tube, expanding the material of the nipple in the reduced zone radially outwards into contact with the tube to occupy the registering cavity in the tube and form a positive lock against tensile forces, and connecting the nipple to the second tube.

It is desired that the nipple be permanently connected at each end of a drill tube, the arrangement mentioned above can be provided at each end.

The step of enlarging the reduced zone of the nipple can be undertaken by the use of any suitable tool such as a roll or a mandrel rammed down the interior of the nipple.

In some versions the nipple may have a boss in its central zone which defines a shoulder against which

the end of the drill tube bears when the nipple is in its final position. In other versions the nipple is free of such a boss and the drill tubes bear on each other end-to-end in the assembled string.

70 The invention also includes a nipple as described above for use in making the connection.

Brief description of the drawings

Figure 1 is a semi-schematic view of a threaded nipple, partly sectioned, inserted at one end into a drill tube.

Figure 2 is a view of the structure of Figure 1 after the step of expanding the reduced zone of the nipple into contact with the drill tube.

80 Figure 3 is a view similar to Figure 1 of a second embodiment in which the nipple has a central boss; and

Figure 4 is a view similar to Figure 2 of the structure of Figure 3.

Description of preferred embodiments

In Figures 1 and 2, a nipple or coupling 10 for connecting two drill tubes 12 in a drill string has a plain central zone 14, a threaded left end 16 accommodated in a threaded end of the tube 12, and a threaded right end 18. The far left end of the nipple forms a zone 20 of reduced internal diameter which registers with an annular cavity or groove 22 in a zone of the tube 12.

Once the nipple 10 is fully inserted into the tube 12 as shown, a mandrel (not shown) is rammed down the interior of the nipple to expand the metal in the zone 20 into contact with the surface of the cavity 22 as seen in Figure 2. In this condition the expanded zone 20A has an internal diameter substantially equal to that of the rest of the nipple, so that the tube interior can be used in the usual fashion for core extraction or for flushing fluid or the like. The diameter of the mandrel will of course be slightly less than that of the bore of the nipple.

The nipple may be as illustrated in Figures 1 and 2 or may also have a zone in the right end corresponding to the opposite zone 20, 20A. This nipple provides a permanent connection to both drill tubes when inserted and expanded, although this is not easy in practice.

In Figures 3 and 4 the structure illustrated is similar to that in Figures 1 and 2, corresponding features being given the same reference numerals preceded by the prefix "1". The nipple 110 has however an annular boss 130 in the centre of the zone 114, and the end of the tube 112 bears against the side of the boss 130 when the nipple is fully inserted.

One end 16 or 18 of the nipple 10 and a corresponding tube end 12 may be provided with a left-hand thread. The joint is then made so that the threads tighten when the tubes are rotated in the high-torsion rotational direction for drilling.

The present invention thus provides a means for joining rigid tubes, the joint being such that an internal hollow remains for coring if necessary. The external diameter of the string of tubes is not increased at the joints and the joint is of a high strength in resisting axial and torsional forces and

bending moments. The recesses 22, 122 may be pre-formed and the only deformation which is necessary when the joint is made (often on site in difficult circumstances) is deformation of the nipple, which may be of a softer metal than the drill tubes. There is no need for welding or brazing or for the use of equipment which must surround the tubes when the joint is made.

10 CLAIMS

1. A method of forming a joint of high strength between two tubes of substantially similar high rigidity by means of a nipple which is no greater in external cross-section than the external cross-section of the tubes comprising forming on one end of the nipple a zone in which the internal diameter is reduced substantially relatively to the remainder of that part of the nipple intended to enter the tube, forming a zone of substantially enlarged inner diameter in a first tube to register with the reduced zone of the nipple, introducing the nipple into that tube, expanding the material of the nipple in the reduced zone radially outwards into contact with the tube to occupy the registering cavity in the tube and form a positive lock against tensile forces, and connecting the nipple to the second tube.
2. A method according to claim 1 including the step of providing a zone of reduced internal diameter at the second end of the nipple, providing a corresponding cavity in a registering zone of the second tube, and expanding the material of the nipple in these zones to connect the nipple to the second tube.
3. A method according to either one of the preceding claims in which the nipple is expanded by ramming a mandrel through it.
4. A method according to any of the preceding claims including the step of threading the nipple and the tubes and screwing the nipple into the tubes before expanding the nipple.
5. A pair of rigid tubes joined by a connection nipple, at least one of the tubes having a zone of enlarged internal diameter defining a cavity and the nipple having a zone of enlarged outer diameter which occupies the cavity, the external cross-section of the nipple being no greater than the external cross-section of the tubes.
6. The tubes and nipple of claim 5, in which the internal diameter of the nipple is substantially constant.
7. The tubes and nipple of claim 5 or claim 6 in which the nipple has a zone of enlarged outer diameter at each end, these zones each occupying a corresponding cavity in a tube.
8. A method according to claim 1 substantially as herein described with reference to Figures 1 and 2 or Figures 3 and 4.
9. A pair of tubes joined by a connection nipple, substantially as herein described with reference to Figures 1 and 2 or Figures 3 and 4.